



Yamaha Eluder/Venture Fog Light Kit

This sheet must be read completely to:

1. Provide assistance/clarification to the installer, customer, end user or others.
2. Avoid causing injury or death to installer, customer, end user, or others.
3. Prevent damage to vehicle and/or accessory or other.

HEY YOU! Please, please, please read the instructions completely prior to installation. 90% of questions we receive could be answered simply by reading ALL the instructions before installing anything. If you have any question or problem during the installation, please contact us as necessary. Phone support will always provide the quickest response. Installation of this product implies your agreement with our sales, warranty, exchange and return policies found on our website.

You can thank the lawyers for this next bit of fun. With that said, lets go!

Installer: Pretty please, give this sheet to the customer after reading it.

It is virtually impossible for us to be able to address every possible situation an installer or user will encounter. This requires both to exercise due diligence and to apply some level of common sense. AKA...no 'hold my beer and watch this' type stuff.

Important Information in our instructions will be provided in the following manner:

SHOP TIP: literally great info we have gathered from hands-on installs or customer feedback.

NOTE: important information regarding the installation. Pay attention.

CAUTION: failure to follow instructions could result in damage to vehicle and/or accessory. Really pay attention.

WARNING: failure to follow instructions could result in injury/death of operator and/or passenger/others. For Pete's sake, PAY ATTENTION!

NOTE:

1. "Left", "Right", "Front" and "Rear" are described from the seated position of the vehicle. Vroom vroom.
2. Check local laws regarding the use of auxiliary lighting and electronics. Don't be 'that guy'.
3. Use of owners manual or service manual is recommended for installation. Sorry....more reading.
4. If so equipped, place motorcycle on it's centerstand on solid, level ground or engage parking brake. Do it like Mom is watching.

CAUTION:

1. When adding electrical accessories, always disconnect the battery and properly fuse new electronics.
2. DO NOT let the smoke out of the part. All electronics operate on smoke....when released, electronics are dead.

WARNING:

1. Allow the vehicle to cool prior to installation & when operating engine, allow adequate ventilation. Yep.
2. NEVER modify the kit in ANY manner. Doing so voids warranty and places all liability on the installer and/or user. Nope.
3. Never route wires or install components that interfere with the operation of the steering, suspension, brake/clutch/gas lever/pedal/grip or any other operational function of the vehicle. Duh.
4. Never allow your accessories to cause distractions to remove your focus off the vehicles operation. Never forget that this is a high risk sport - don't make it a higher risk when you don't have to. Major duh.
5. Never allow your accessories to cause distractions to others on the road. Super sized duh.

Part Listing

- | | |
|---|----------------------------|
| 2 | light housing |
| 1 | relay. |
| 2 | 'christmas tree' fasteners |

Tools / Supplies Required

- metric allen wrench set
screwdrivers.

1. Remove bottom cowl panels, rear section.
Remove the one screw and 2 push fasteners.
Push fasteners can be removed by pushing in the center of the fastener with a pointed tool.
Then remove the fastener from the panel.
Repeat other side.

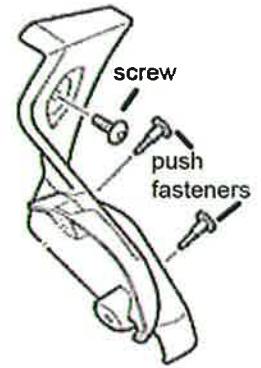

2. Remove bottom cowl panels, front section.
Remove the one screw and one push fastener.
Repeat other side.

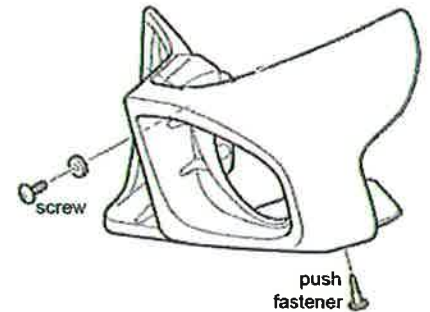

3. Remove the dead panel & install light.
Remove the 4 screws that hold the dead panel to the front section of the bottom panel. Retain the 4 screws.
Mount your new light using the OEM screws. The gold adjustment screw on the back of the light housing needs to be positioned at the 7 o'clock position.
See pic at right for reference.
Repeat other side.

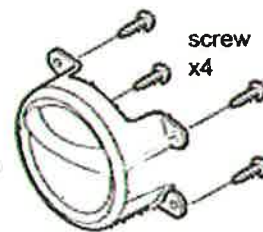

Note: to reinstall the push fasteners, do the following before inserting into the hole.
Hold the base of the fastener while you push up on the center of the pin.
Once it is pushed up, insert the fastener into the hole.

4. Connect light to bike's wiring.
Left side of the bike is show in the pic.
Using the pic shown to the right, find the connection inside the rubber boot.
Remove the dead plug from the connector. Connect the light to the harness.
Reinstall the front cowl section with the light attached.
Do not install the rear section yet.
Repeat other side.

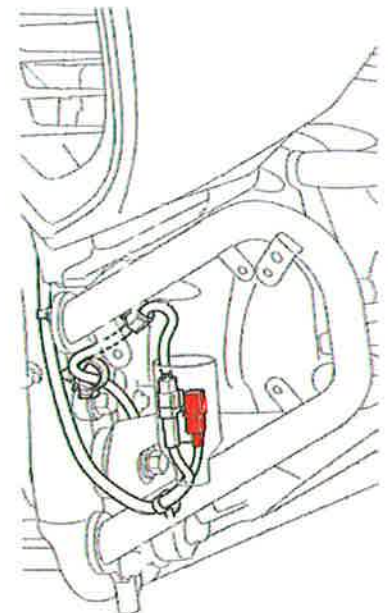

5. Access the relay bank.

Remove the left saddlebag by removing the 4 bolts shown.

Unplug the connector from the saddlebag to the OEM wiring.

Move the saddlebag out of your way and place it on a towel or blanket.

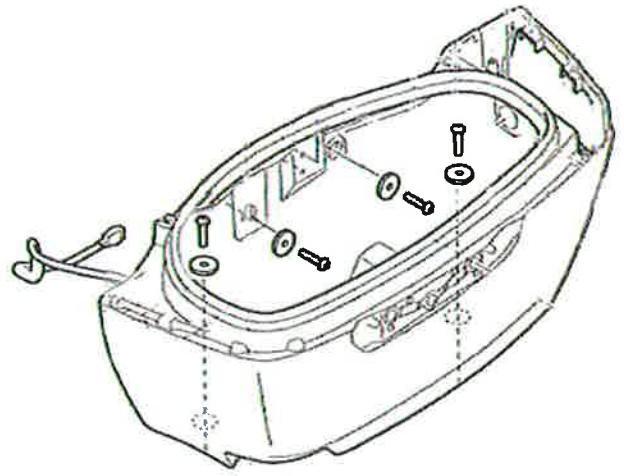

6. Install relay.

Note the position of the fog relay will install in red.

Remove the dead plug.

Connect the included relay to the OEM wiring.

Secure the relay to the relay bank.

Reinstall the saddlebag.

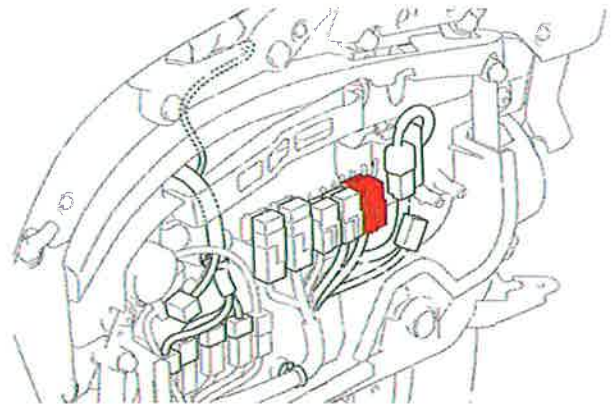

7. Aim your lights.

Turn key on.

Make sure high beams are OFF.

On the back side of the left handlebar control, you will find the ON/OFF switch for the fog lights.

Turn fog lights on.

Using the gold adjustment screw on the back of the light housing, adjust your lights.

Clockwise will adjust the light beam up, counter-clockwise will adjust the light beam down.

8. Reinstall rear cowl section.

Note that one of the holes where you would normally install a push fastener will no longer accommodate it.

Use the supplied 'christmas tree' fastener.

Cut some of the shaft off using a set of side cutters until you are able to push the fastener all the way in the hole.

Repeat other side.